



# DIAMANT

*Pesage et*  
métiers de bouche

***A música está em tudo. Do Mundo sai um hino.*** Victor Hugo

Com uma ampla superfície de exposição e elevada visibilidade, a Vivaldi é o palco onde os seus produtos ganham destaque.

Nas versões refrigerada (frio estático ou ventilado), padaria, banho-maria, covetes refrigeradas e placa quente, esta vitrina oferece não só uma diversidade de soluções de exposição mas também diferentes acabamentos, cores e acessórios, permitindo a concretização dos seus desejos.

Para espaços acolhedores, onde os encontros acontecem e apetece permanecer...

***La música está en todo. Del Mundo sale un himno.*** Victor Hugo

Con una amplia superficie de exposición y elevada visibilidad, Vivaldi es el escenario donde sus productos ganan destaque.

En las versiones refrigerada (frío estático o ventilado), panadería, baño-maría, cubetas refrigeradas y placa caliente, esta vitrina ofrece no sólo una diversidad de soluciones de exposición sino también diferentes acabados, colores y accesorios, permitiendo la concretización de sus deseos.

Para espacios acogedores, donde los encuentros acontecen y apetece permanecer...

***Music is in everything. A hymn comes forth from the earth.*** Victor Hugo

With a large display area and a high visibility, Vivaldi is the stage where your products are highlighted.

In the versions refrigerated (fan assisted or static), bakery, "bain-marie", refrigerated-gastronorm-containers and hot plate, this display case offers not only a variety of exposure solutions but also different finishings, colors and accessories, allowing the achievement of your wishes.

For cozy spaces where meetings happen and people wish to remain in...

***La musique est dans tout. Un hymne sort du monde.*** Victor Hugo

Avec une grande surface d'exposition et grande visibilité, la vitrine Vivaldi est le stade où ses produits sont mis en évidence.

Dans les versions réfrigéré (froid statique ou ventilé), boulangerie, bain-marie, bacs réfrigérés et plaque chaude, cette vitrine non seulement offre une variété de solutions, mais également des différentes finitions, couleurs et accessoires, permettant la réalisation de vos désirs.

Pour les espaces accueillant où les réunions ont lieu et les personnes, ont envie de rester...

***Die Musik ist in allem. Von der Erde erklingt eine Hymne.*** Victor Hugo

Mit einer breiten Ausstellungsfläche und optimalen Übersicht der ausgestellten Waren ist die Kühlvitrine Vivaldi die perfekte Lösung für eine ansprechende Präsentation Ihrer Produkte.

Erhältlich in verschiedenen Ausführungen, ob als gekühlte Version (mit statischer oder Umluftkühlung), als Backwarenvitrine, mit Bain-Marie, Gekühlte Gastronormbehälter oder Warmhalteplatte, bietet sie nicht nur individuelle Ausstellungslösungen, sondern auch verschiedene Bearbeitungen, eine große Farbauswahl und vielfältiges Zubehör. Somit wird eine persönliche Gestaltung nach ihren Wünschen möglich.

Für einladende Räume, wo man sich durch Zufall trifft und doch verweilen möchte...

# DIAMANT

classica vve

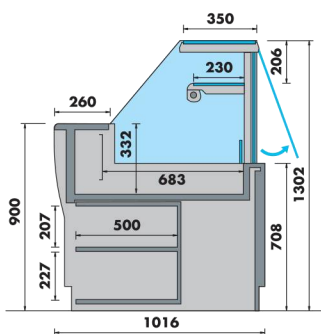

# DIAMANT

scala vc

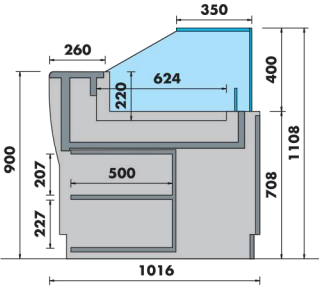

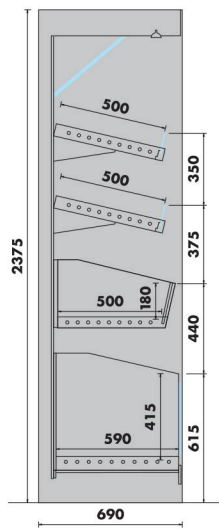
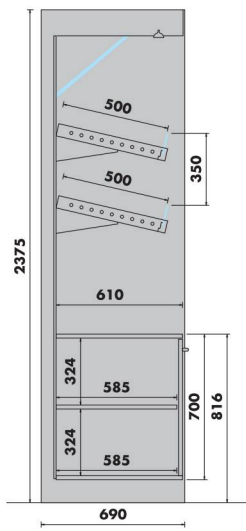

RETRO MODULAR  
MODULAR RETRO

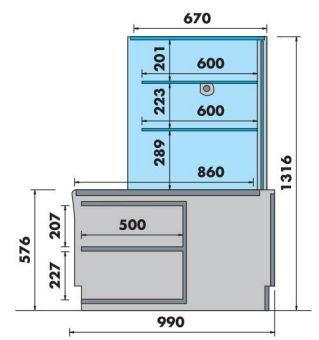
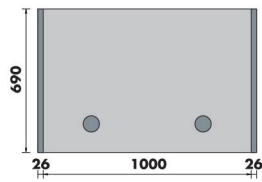

TORRE N VVP  
TOWER N VVP

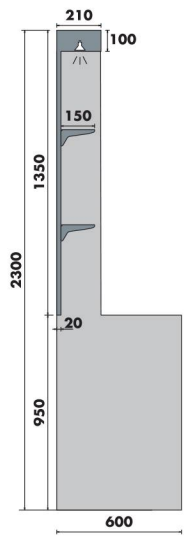

RETRO BOLERO

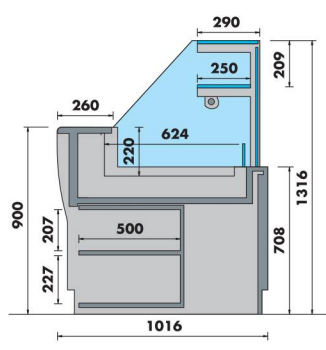

CH VVP

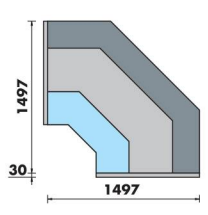

INT 90° VVP

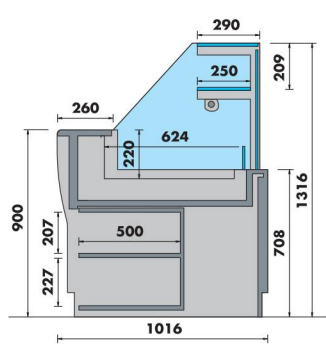

FV VVP



# DIAMANT

clássica vvp



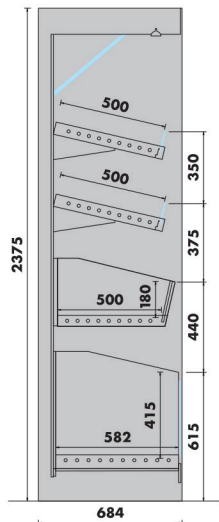

RETRO MODULAR

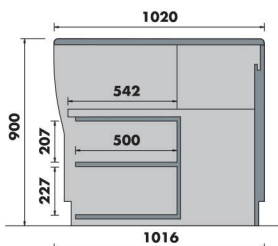

MESA TERMINAL / CASH DESK

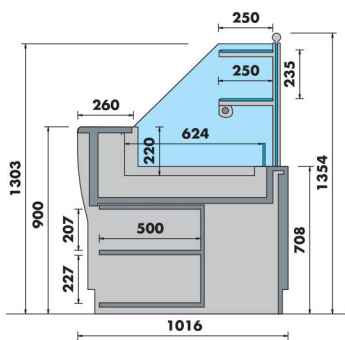

FV VV

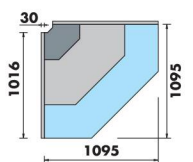

EXT 90° VV

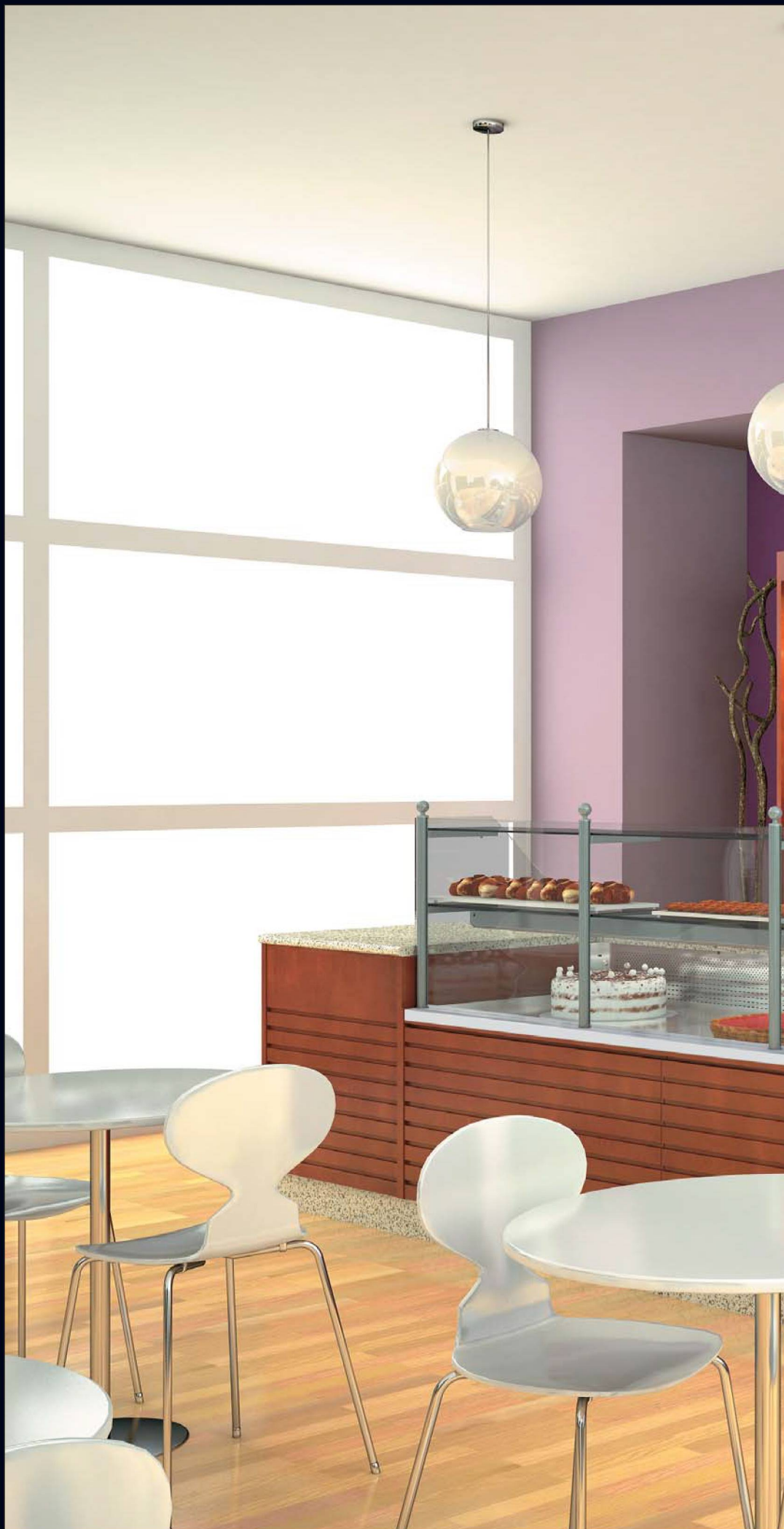



# DIAMANT

scala vv



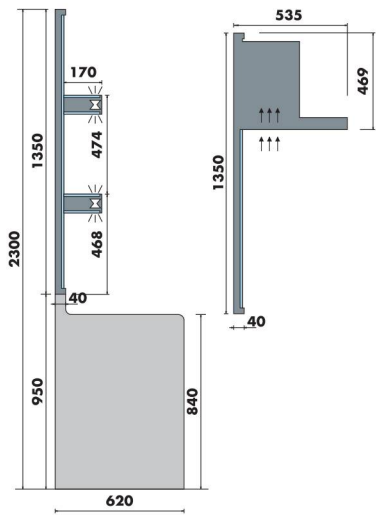

RETRO VALSA

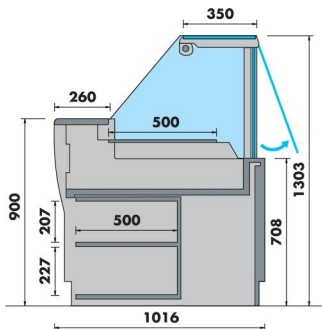

PQ VVE

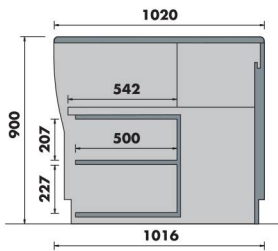

MESA TERMINAL / CASH DESK

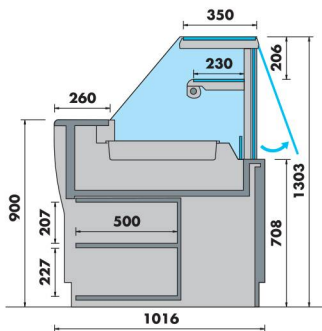

CR VVE

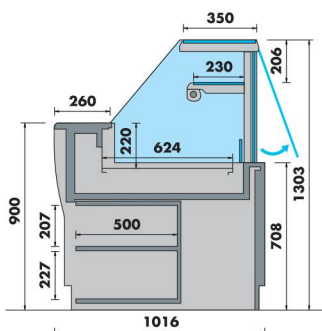

FV VVE



DIAMANT  
clássica vve





# DIAMANT

clássica vv



- Refrigeração ventilada (FV) ou estática (FE) com grupo compressor incorporado
- Descongelação automática
- Evaporação automática da água de condensados
- Vidros verticais (VV), verticais planos (VVP), verticais de elevação (VVE) ou colados (VC)
- Suporte de vidros em perfil de alumínio anodizado
- Resistência de desembaciamento no vidro frontal
- Iluminação LED nas prateleiras
- Tampo superior em vidro
- Plano de exposição em inox brilhante
- Tampo de trabalho e rodapé em inox, mármore ou granito
- Reserva neutra aberta com prateleira amovível
- Controlador eletrónico de fácil comando
- Multiplex
- Outras versões disponíveis: chocolates (CH), cuvetes refrigeradas (CR), banho-maria (BM), placa quente (PQ), padaria (PAO), neutra (N) e torre neutra

- Refrigeración ventilada (FV) o estática (FE) con grupo compresor incorporado
- Descongelación automática
- Evaporación automática del agua de condensados
- Cristales verticales (VV), verticales planos (VVP), verticales elevables (VVE) o pegados (VC)
- Soporte de cristales en perfilería de aluminio anodizado
- Resistencia anti-condensación en el cristal frontal
- Iluminación LED en los estantes
- Encimera en vidrio
- Plano de exposición en acero inox brillante
- Tablero de trabajo y zócalo en acero inox, mármol o granito
- Reserva neutra abierta con estante extraíble
- Controlador electrónico de fácil manejo
- Modular
- Otras versiones disponibles: chocolates (CH), cubetas refrigeradas (CR), baño-maria (BM), placa caliente (PQ), panadería (PAO), neutra (N) y torre neutra

- Fan assisted (FV) or static (FE) refrigeration with built-in group
- Automatic defrosting
- Automatic evaporation of defrost water
- Vertical (VV), flat vertical (VVP), lift-up vertical (VVE) or glowed glasses (VC)
- Glass support in aluminium anodize profile
- Anti-mist heating elements for front glass
- LED lighting in shelves
- Glass top
- Display deck in bright stainless steel
- Working top and plinth in stainless steel, marble or granite
- Neutral under storage with removable shelf
- Easy to use electronic controller
- Multiplexable
- Other versions available: chocolates (CH), refrigerated-gastronorm-containers (CR), bain-marie (BM), hot plate (PQ), bakery (PAO), neutral (N) and neutral tower

- Réfrigération ventilée (FV) ou statique (FE) avec groupe logé
- Dégivrage automatique
- Évaporation automatique de l'eau de dégivrage
- Vitres verticales (VV), verticales droites (VVP), verticales relevables (VVE) ou collé (VC)
- Support de vitre en profil en aluminium anodisé
- Résistance anti-buée dans les vitres frontales
- Éclairage LED dans les étagères
- Tablette supérieure en verre
- Plan d'exposition en acier inox brillant
- Tablette de service et plinthe en acier inox, marbre ou granite
- Réserve ouverte neutre avec étagère amovible
- Régulateur électronique facile à utiliser
- Multiplex
- Autres versions disponibles: chocolats (CH), bacs réfrigérés (CR), bain-marie (BM), plaque chaude (PQ), boulangerie (PAO), neutre (N) et tour neutre

- Umluftkühlung (FV) oder stille Kühlung (FE) mit integriertem Kompressoraggregat
- Automatische Auftauung
- Automatische Kondenswasserverdunstung
- Vertikale Scheiben flach (VVP), vertikale (VV), zum anheben (VVE) oder geleimt (VC)
- Glasunterlage mit eloxiertem Aluminiumprofil
- Widerstände gegen Beschlagen der Frontscheiben
- LED-Beleuchtung an allen Regalböden
- Oberer Deckel aus gehärtetem Glas
- Präsentierfläche aus glänzendem Edelstahl
- Arbeitsplatte und Sockelleisten aus Edelstahl, Marmor oder Granit
- Offenes Reservefach mit abnehmbarem Regalboden
- Leicht zu bedienender elektronischer Regler
- Multiplex
- Andere verfügbare Ausführungen: Chocolates (CH), gekühlte Gastronormbehälter (CR), Wasserbad (BM), Hitzeplatte (PQ), Backwarenplatte (PAO), Neutral (N) und Neutralturm

## DIAMANT FV

MODELO MODELO MODEL MODÈLE MODELL	COMPRIMENTO TOTAL LONGITUD TOTAL TOTAL LENGTH LONGUEUR TOTAL GESAMTLÄNGE (mm)	COMPRIMENTO SEM LATERAIS LONGITUD SIN LATERALES LENGTH WITHOUT SIDE PANELS LONGUEUR SANS JOUÉS LATÉRALES LÄNGE OHNE SEITENWÄNDE (mm)	ÁREA TOTAL DE EXPOSIÇÃO (TDA) SUPERFICIE TOTAL DE EXPOSICIÓN (TDA) TOTAL DISPLAY AREA (TDA) SURFACE TOTALE DE L'EXPOSITION (TDA) WARENPRÄSENTATIONSFLÄCHE (TDA)			ÁREA DE EXPOSIÇÃO REFRIGERADA SUPERFICIE DE EXPOSICION REFRIGERADA REFRIGERATED DISPLAY AREA SURFACE D'EXPOSITION RÉFRIGÉRÉE GEKÜHLTE AUSLAGEFLÄCHE (m <sup>2</sup> )	CLASSE DE TEMPERATURA CLASE DE TEMPERATURA TEMPERATURE CLASS CLASSE DE TEMPÉRATURE TEMPERATURKLASSE
			VVP / VC	VVE	VV		
DIAMANT 960	1020	960	0,51	0,45	0,55	0,60	M2
DIAMANT 1210	1270	1210	0,64	0,57	0,69	0,76	M2
DIAMANT 1420	1480	1420	0,75	0,67	0,81	0,89	M2
DIAMANT 1920	1980	1920	1,02	0,91	1,1	1,20	M2
DIAMANT 2420	2480	2420	1,29	1,14	1,38	1,51	M2
DIAMANT 2840	2900	2840	1,51	1,34	1,62	1,77	M2

CLASSE CLIMÁTICA / CLASE CLIMÁTICA / CLIMATIC CLASS / CLASSE CLIMATIQUE / KLIMAKLASSE: 3 (+25°C / HR 60%) GAS: R404A

## Tampos e Rodapés

Working Tops and Plinths

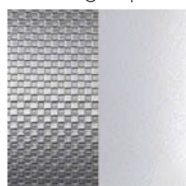

Inox  
Stainless Steel



Granito Moca  
Granite Moca

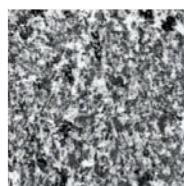

Granito Preto Nacional  
Granite Preto Nacional



Pedra Láctea  
Stone Láctea



Pedra Cinza  
Stone Cinza



Mármore  
Marble

## Decorações Lacados

Lacquered Decors



RAL 1012



RAL 1013



RAL 2001



RAL 3000



RAL 5000



RAL 5023



RAL 6011



RAL 6017



RAL 7035



RAL 7040

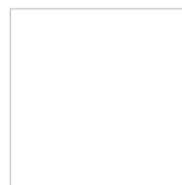

RAL 9003



RAL 9005

## Decorações Madeira

Wooden Decors



Carvalho  
Oak



Faia  
Beech

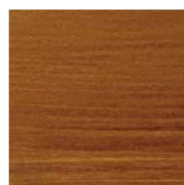

Cerejeira  
Chery



Wengué  
Wengue



Cortiça  
Cork

## Decorações Laminados

Laminated Decors



Carvalho  
Oak

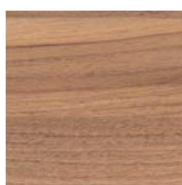

Nogueira  
Walnut



Zebrano

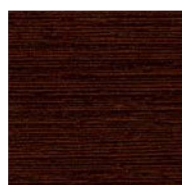

Wengué Moçambique



Atlas



Preto  
Black

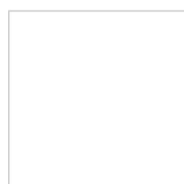

Branco  
White



Vermelho  
Red



[www.pesage-mb.com](http://www.pesage-mb.com)  
[Contact@pesage-mb.com](mailto:Contact@pesage-mb.com)  
Tel : 04.66.30.09.72